



# WALLPACK LED 150W



## DESCRIPCIÓN

Luminario tipo Wallpack con Tecnología LED, apto para uso en entornos exteriores, resistente a la corrosión, de fácil instalación, esmaltado en color café.

## CARACTERÍSTICAS ELÉCTRICAS

Código	WL15065XXX
Potencia	150W
Tensión	120-277V~50/60Hz
Ángulo de Apertura	120°
Temperatura de Trabajo	-30°C a 50°C
Factor de Potencia	0.9

## CARACTERÍSTICAS FÍSICAS

Color	Café
Montaje	Sobreponer
Difusor	Policarbonato
Material	Aluminio

## CARACTERÍSTICAS LUMÍNICAS

Código	WL15065XXX
Temperatura de Color	6500°K
Flujo Luminoso	18,000 LM
Vida útil	50,000 Hrs



LED

NOM



## DIMENSIONES

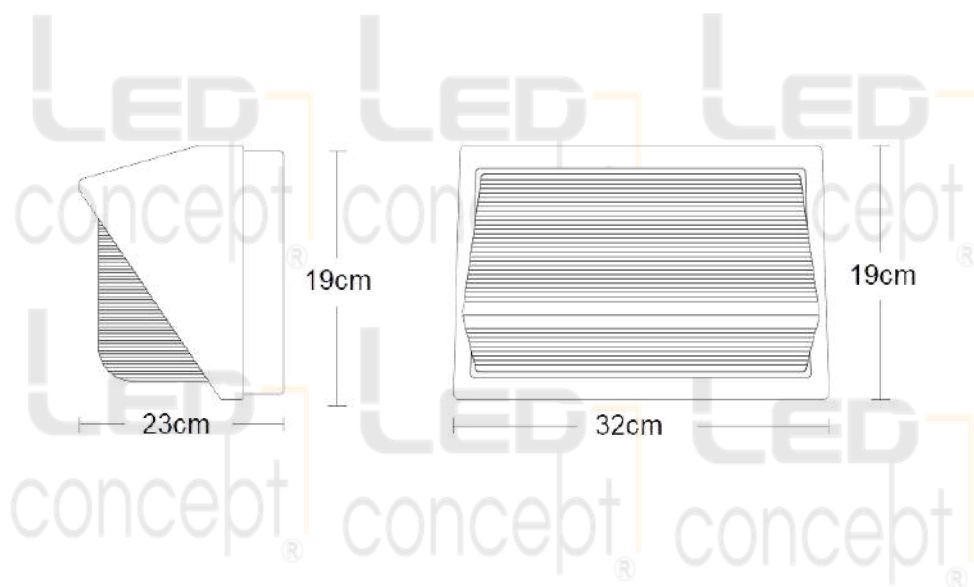

## APLICACIONES



Fachadas

Estacionamientos y  
Cocheras

Bodega



Jardines

## COMPLEMENTOS

Piezas por caja	1 pz
Peso por caja	3.5 Kg
Medidas por caja (cm)	41 x 24 x 29
Garantía	2 años



IP 65

LED

NOM



2

AÑOS  
DE GARANTÍA